

Technical Specifications for IrisAccess System

System Configuration

The IrisAccess system consists of iData EAC(Entry Access Control) Software & proprietary hardware that pairs specifically with our software suite. Several hardware components can be used: iCAM4000 series, iCU4000 series, iCAM7000 series and functional operational mode options can be used.

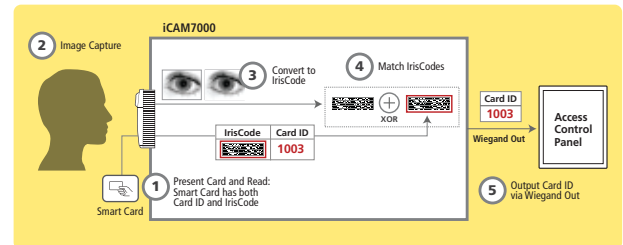
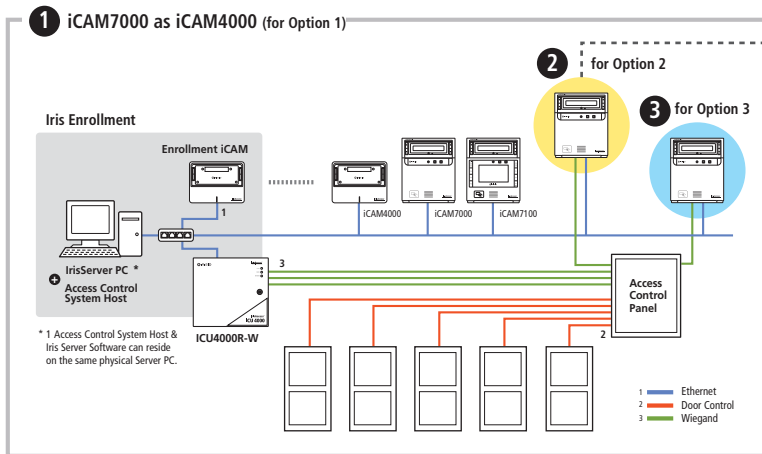

- 1** Option 1: Networked iCAM Control / Iris Matching Mode
- 2** Option 2: Smart Card On-Device Verification Mode
- 3** Option 3: On Device iCAM Control and Iris Matching Mode

Technical Overview

The iCAM7000 series contains an optical system designed to operate with the integrated high-speed multi-sensor iris imager array. The iCAM7000 series will automatically process and output high quality ISO standards compliant iris images of a subject in less than one second.

iCAM7000 series (IrisCamera)

Dimensions (W x H x D)	7.01" x 8.31" x 2.52" (178mm x 211mm x 64mm)
Weight	3.5lbs (1.6kg)
Power Input / Consumption	12-24 VDC, 2.0 Amps @ 12 VDC / 24W
Status LED	Multi Color - Red, Green, Blue for status indication
Iris Operating Range Indicator	Dual Color - Orange (out of range), Green (in range)
Voice Indication	English standard, others available by download
Iris Capture Range	12" - 14" (31cm - 35cm)
User Input	Function keys six user definable (iCAM7100)
Touch Screen LCD Display	4.3" (480 x 272 pixels) (iCAM7100)
Pin Pad	Pop-up on screen pin pad (iCAM7100)
Flash	High output flash for face capture
Face Image Camera	Face camera - 5MP
Transaction Log Capacity	Up to 100K FIFO transactions stored on device, unlimited on server
Relays x 2	Control for user defined operations
External Media Device Connectivity	Secure user accessible USB port
Operating Temperature	32°F - 113°F (0°C - 45°C)
Storage Temperature	-4°F - 203°F (-20°C - 95°C)
Humidity	Up to 90% non-condensing
Iris & Face Camera Rotation Angle	+35°/-25°
Communications	Ethernet (LAN, WAN), RS422 (output only), RS232 (input only from external card readers)
Inputs / Outputs	Proximity Card Reader (Wiegand In), Embedded Smart Card Reader (Optional), Wiegand In, Wiegand Out, Dry Contact Relay x 2, Programmable GPIO x 4
Equipment Supplied with iCAM7000	Instruction Manual - Hardware Guide
IrisAccess EAC Server, iData SDK	Refer to IrisAccess Control Software specifications

IrisServer PC Requirements

Operating System	Windows® 7/Vista/XP/Server2003/Server2008
Processor	Pentium®IV 1.6GHz or higher
Memory	512MB or higher
Hard Disk	10GB or higher
Ethernet	10/100Mbps Full Duplex

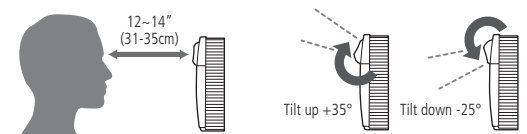
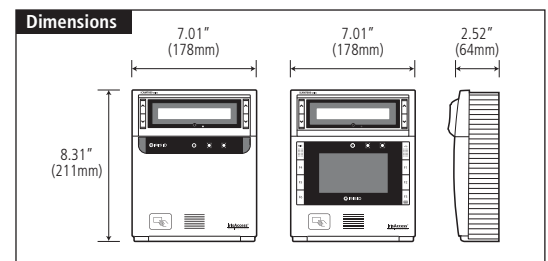

The on-unit up/down tilt buttons can be used to adjust the tilt angle; or an external mounted switch can be wired to control up/down tilt via GPI.

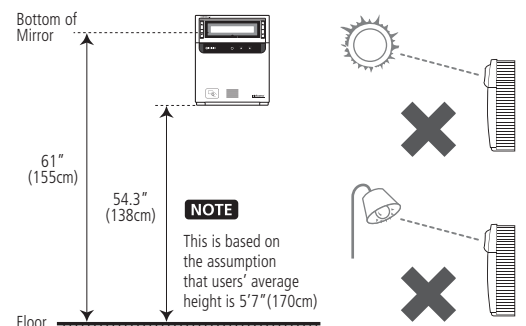

Recognition Modes

Iris in the 1:N search identification mode

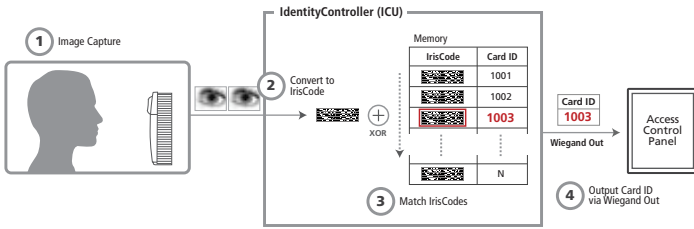

Iris in the 1:1 verification mode with a PIN

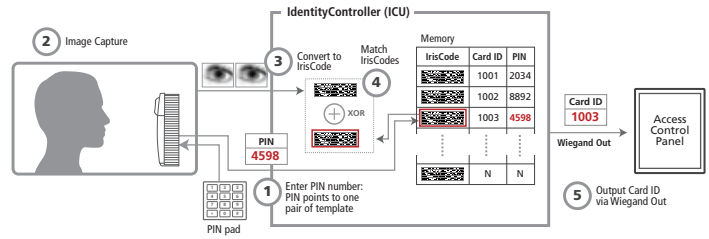

Iris in the 1:1 verification mode with a prox card

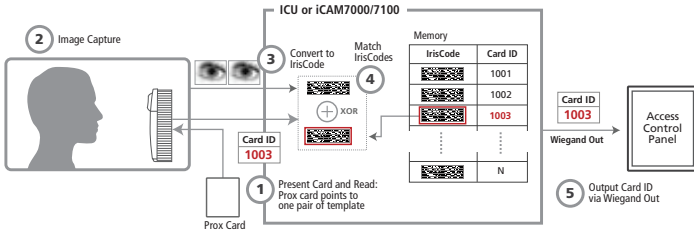

Iris in the 1:1 verification mode with a smart card

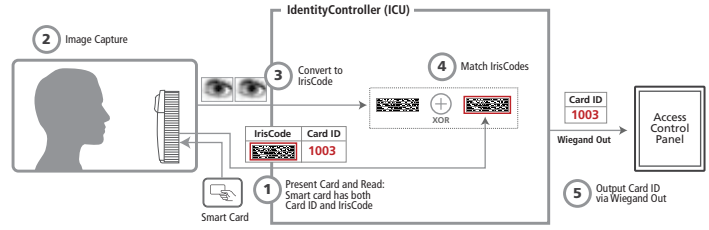

Multi-factor Authentication

Multi-factor authentication can be easily set by using a combination of EAC software, iCAM7100 with built in keypad and leveraging a third party Physical Access Control System (PACS) that can support Card + PIN as an authentication mode. The result is authentication by Card + Iris + PIN. All iCAM models can be used with preinstalled external readers that output wiegand to offer 2 and 3 factor authentication solutions. Specific settings can be found in the iCAM7000 series user guide under multi-factor authentication options.

3 Factor Authentication: iCAM7100 with PACS System (PACS PIN)

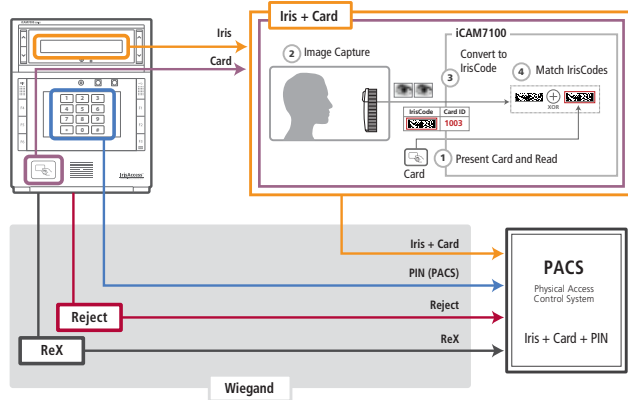

2 Factor Authentication: iCAM7100 without PACS System (Local PIN)

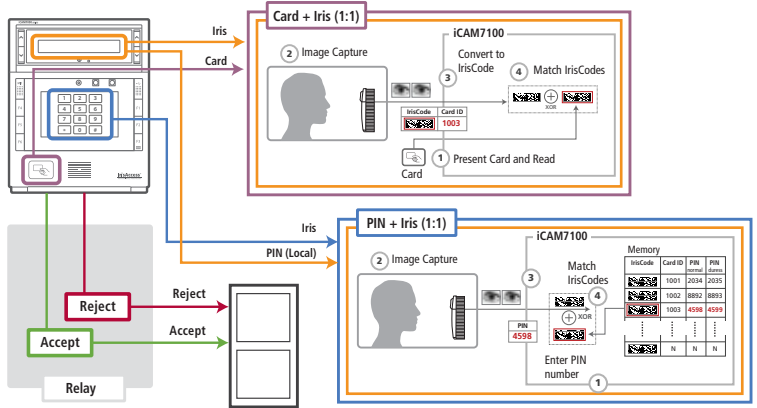

Eye Safety

Iris ID's success as a designer and manufacturer of high quality iris recognition solutions for over 15 years is reflected by the global leadership and adoption of Iris ID products. Continual review of market needs, human factors requirements and precise engineering enable Iris ID to deliver market leading solutions. Iris ID products have always met or exceeded all US and international eye safety requirements. The optics and subtle illumination produced by IrisAccess products have been thoroughly tested and found to fall well within UL and ANSI eye safety standards.

iData™ EAC Software Features

- Enrollment: Simple and flexible administrative user interface for enrollment.
- Setup: Improved software setup and configuration tools for ease of installation.
- Reporting: Individuals are identified as their biometrics are presented. Transactions are stored in the system log and can be downloaded by a system administrator. Logs can also be integrated into an HR time keeping system. IrisMonitor™ provides real time access reporting for multiple iCAM7000 series devices.

Aditech Ltd.

Unit 7 Midshires Business Park, Smeaton Close,
Aylesbury, Bucks, HP19 8HL. UK

www.aditech.co.uk
Tel: +44 (0)1296 398085 - Fax: +44 (0)1296 337755